

PCI-PULVERIZED COAL INJECTION UPGRADING: THE IMPORTANCE OF THE CORRECT TECHNICAL AND ECONOMIC DEFINITIONS*

Joaquim Luiz Monteiro de Barros¹
Fabiana Moreira Costa²
Gustavo Lara Dias³

Abstract

In the production of pig iron, Blast Furnace is the most important equipment and the Pulverized Coal Injection is an important system in this process.

This paper aims to present the importance of the conceptual / basic study and definition of the scope so that the Pulverized Coal Injection (PCI) upgrading service reaches the operational, efficiency, security and economic viability objectives.

Keywords: Blast Furnace; Pulverized Coal Injection (PCI); Upgrading.

¹ COO, Kuttner do Brasil, Contagem, Minas Gerais, Brazil.

² Project Analyst, Kuttner do Brasil, Contagem, Minas Gerais, Brazil.

³ Commercial Assistant, Kuttner do Brasil, Contagem, Minas Gerais, Brazil.

1 INTRODUCTION

In the world production of pig iron, the Blast Furnace (BF) is the most important process. The energy necessary in this process is mainly covered by coke, but a significant measure to reduce the coke rate, CO₂ emissions and operational costs can be achieved with efficient Pulverized Coal Injection through the tuyeres into the BF.

1.1 PCI System

PCI is a complex system with several equipment. Normally, the first step is “coal grinding and drying” according to Figure 1.

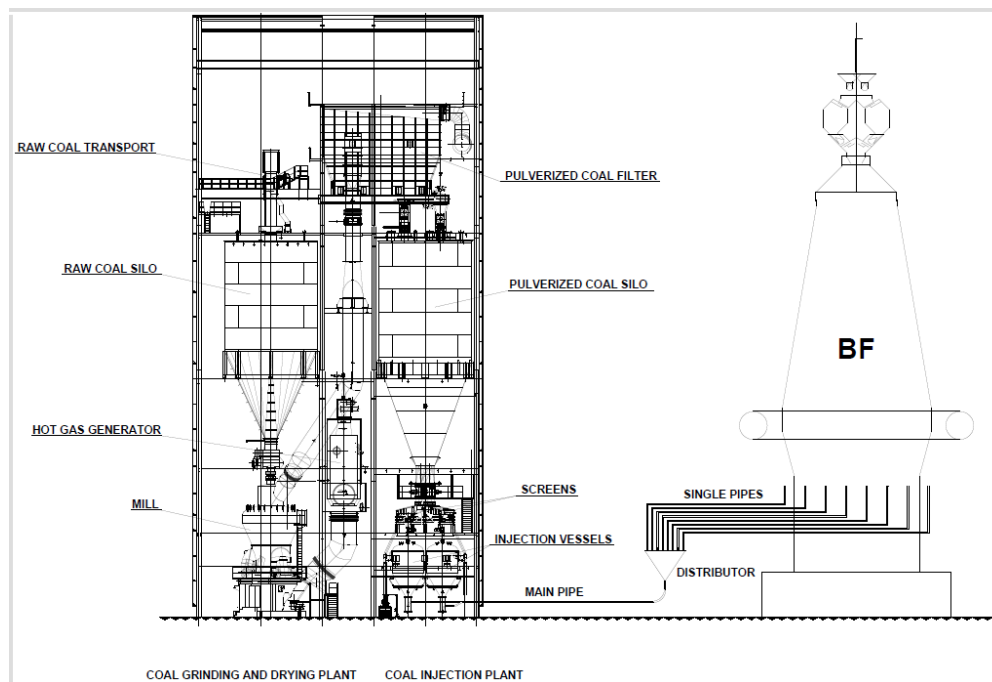

Figure 1. Coal grinding / drying and PCI plant with main pipe system.

The pneumatic transport and injection system may have some designs according to specific objective and technologies. In the figures below we can see some examples:

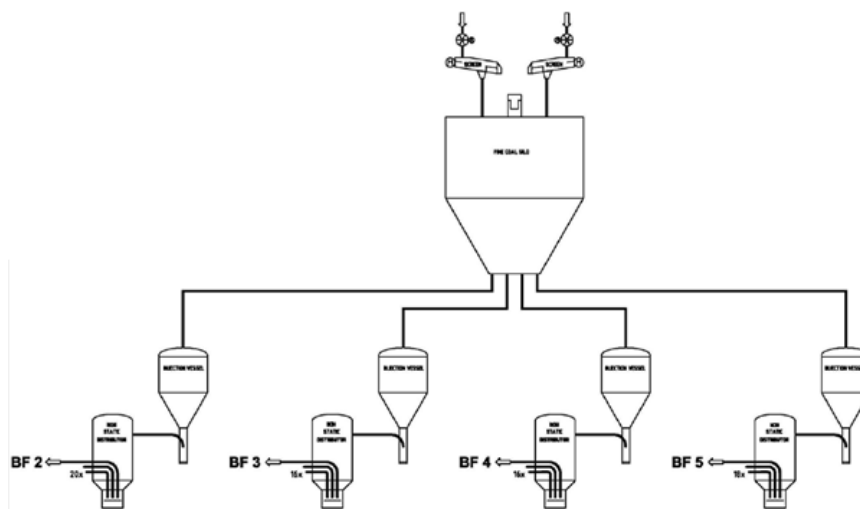

Figure 2. System with distributor vessel (E.S.C.H. type).

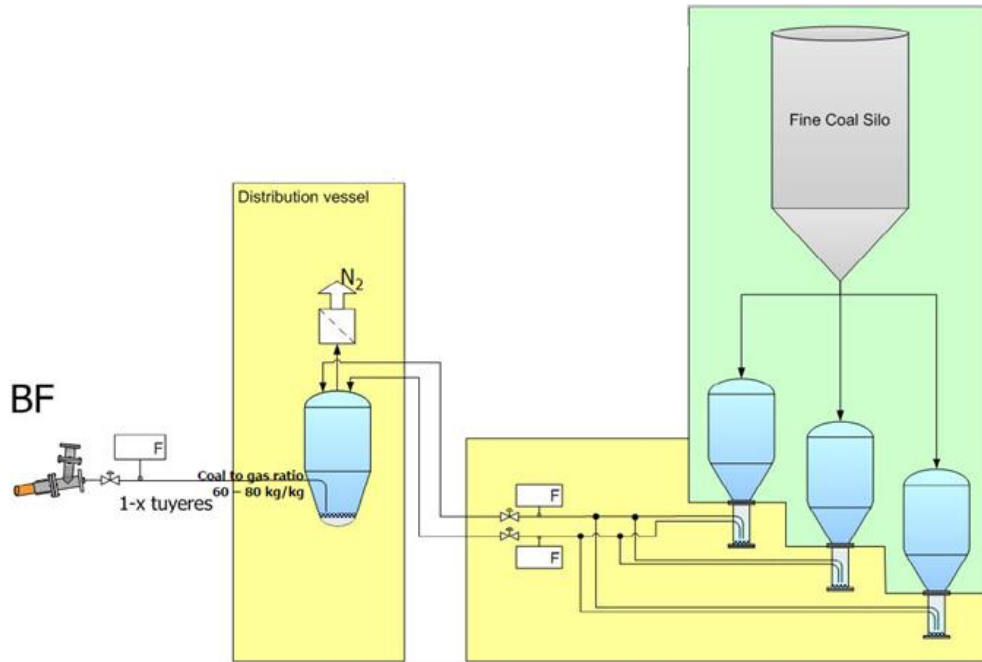

Figure 3. PCI+® set up with distributor vessel and single line control.

There are some technologies for the injection system with different control philosophies and type of tuyeres. In the figure below we can see an example:

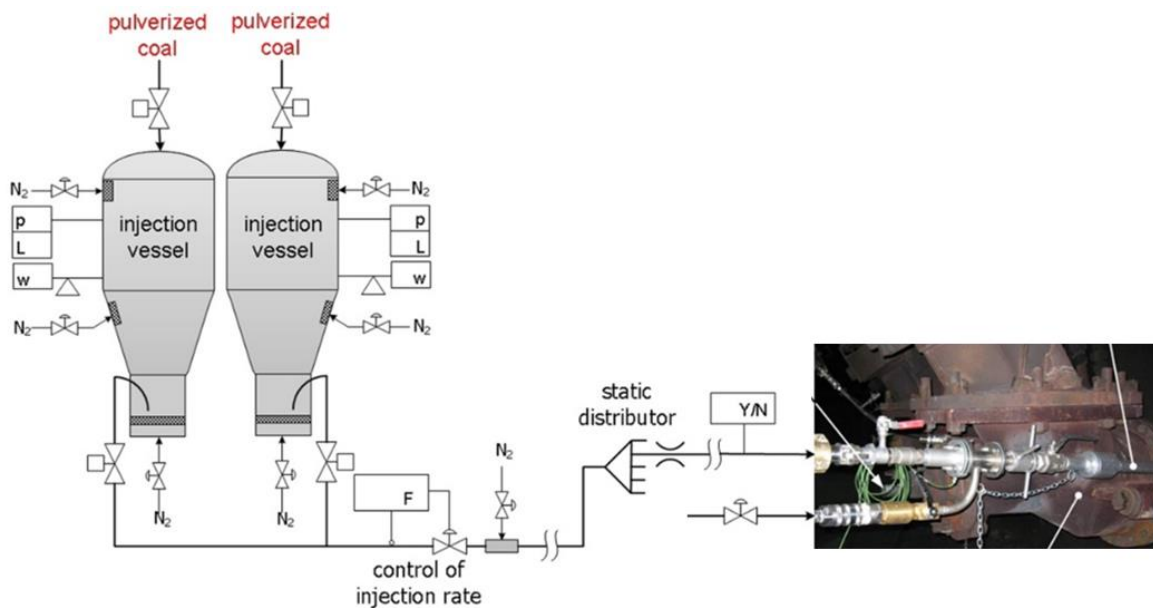

Figure 4. Pulverized coal injection system with Oxycoal+ technology.

1.2 PCI Upgrading

In short, we can say that the PCI upgrading project life cycle follows the steps according to the figures below.

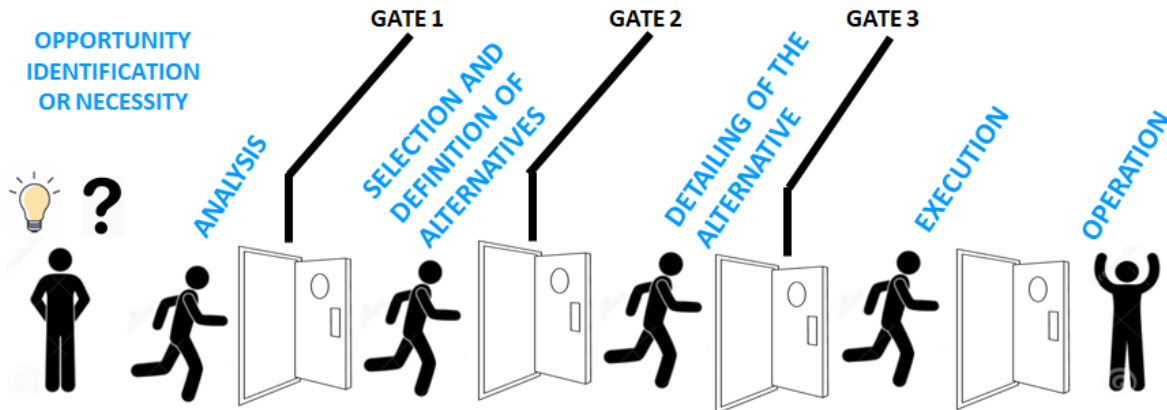

Figure 5. Project Life Cycle.

OPERATION	\$ \$ O U \$ \$ \$ \$ \$ \$		START-UP
EXECUTION	\$ \$ \$ \$ \$ \$ \$ \$		PURCHASE OF EQUIPMENT, CIVIL WORK AND ASSEMBLING
DETAILING OF THE ALTERNATIVE	\$ \$ \$	3	DETAILED ENGINEERING
SELECTION AND DEFINITION OF ALTERNATIVES	\$ \$	2	CONCEPTUAL AND/OR BASIC ENG
DATA ANALYSIS	\$	1	ANALYSIS OF NEEDS AND/OR OPPORTUNITIES
STEPS	\$	GATES	ACTIVITIES

\$: Investment | \$: Investment Return

Figure 6. Project Life Cycle – Investment Gates - Activities.

1.2.1 The Importance of Gate 2 in the Project Life Cycle

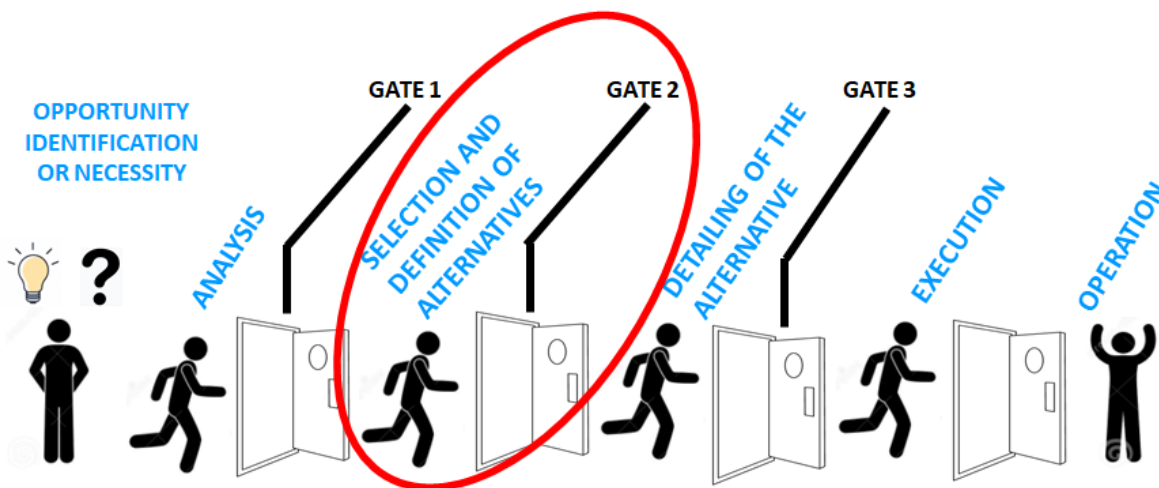

Figure 7. Gate 2.

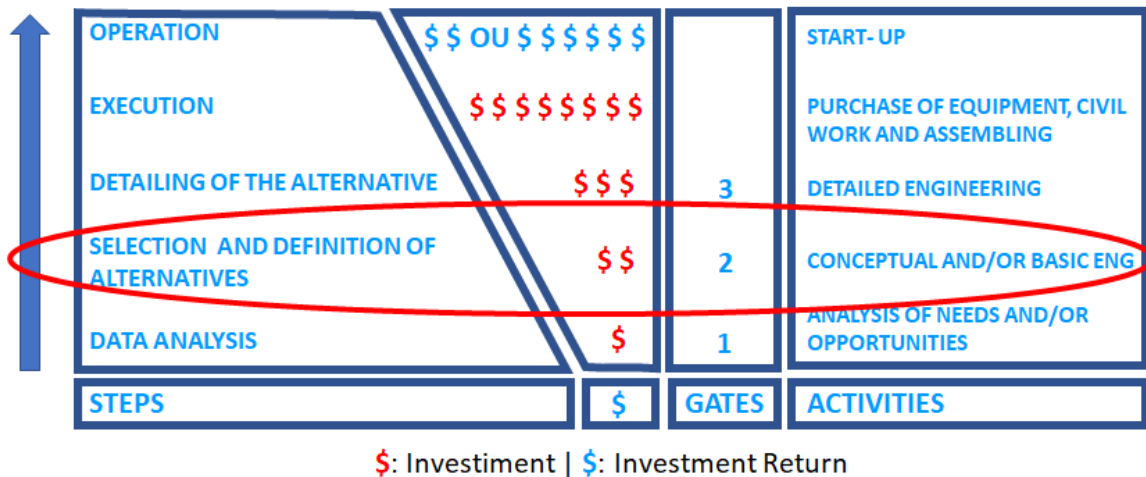

Figure 8. Gate 2.

In this step is necessary to prepare a set of documents that define the project design and conceptual scope, with adequate level of information, until its basic technical feasibility and preliminary assessment of the cost and deadline.

The gate 2 is the moment that technical team will study the actual installation, its problems and limitations, as well as define the project and operating conditions required after the upgrading.

It can be seen that gate 2 has a low investment but it will have great importance in the technical success and in the investment return of the project.

2 Upgrading PCI Project Development Gate 2

2.1 Initial Basic Definitions

The first and most important step for consolidating the PCI upgrading service scope is the initial basic definitions. In this phase of the project, the participation of the engineering, operation and maintenance teams is essential.

In general, the main points that must be defined in this phase are:

- Capacity;
- Injection rate / coke rate;
- Identification of existing technical problems for the definition of possible solutions;
- Safety requirements;
- Environmental requirements;
- Level of integration and automation;
- Schedule with project, purchase, assembly and start-up deadlines;
- Assumptions for the future operation.

2.2.4 Injection System

In this process the pulverized coal is conveyed pneumatically in the dense phase and it is injected into turbulence zone of the Blast Furnace through tuyeres. The figure below shows an example of this system:

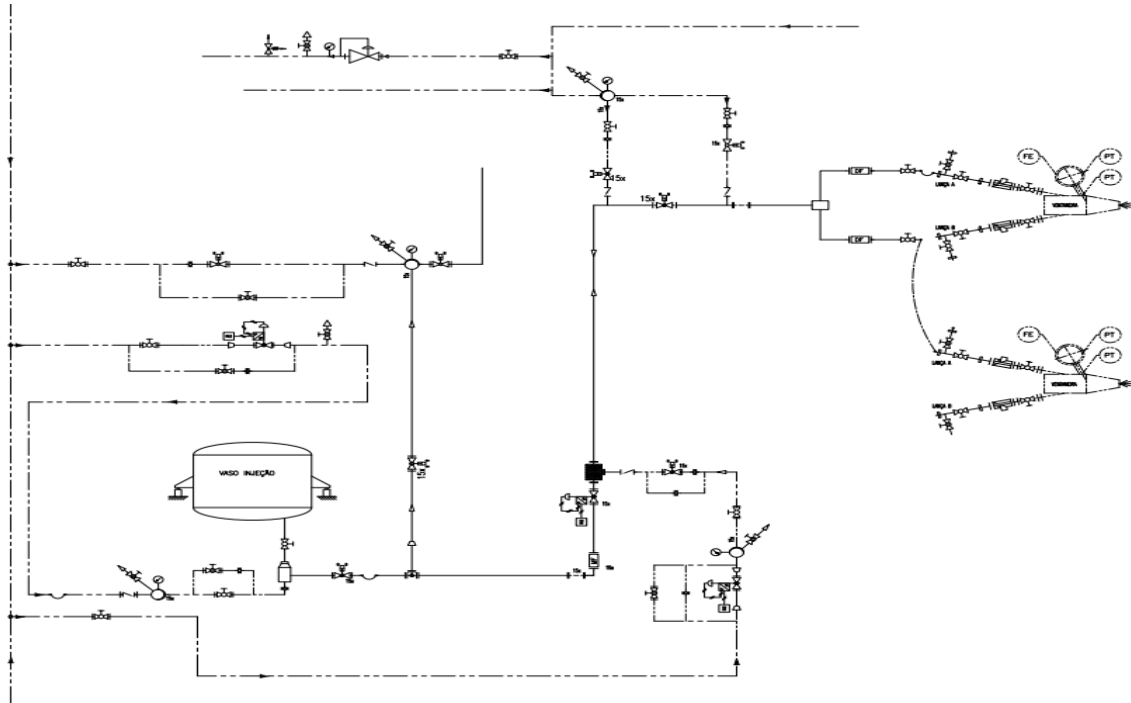

Figure 12. Injection System.

Based on the definitions and data from 2.1 item, the points below must be analyzed to define specific scope of injection system:

- Injection technology and philosophy;
- O₂ injection (now or in the future);
- H₂ injection (now or in the future);
- Charcoal injection (now or in the future);
- Tuyeres design;
- Automation and control.

2.2.5 Others

The points below must also be analyzed to define the upgrading service:

- Planning engineering;
- EPC schedule;
- Civil project;
- N₂ system;
- Fuel gas system;
- Electrical power and control systems;
- Automation;
- Instrumentation;
- Transport;
- Civil work;
- Assembly;
- Try out;
- Start-up.

3 CONCLUSION

We know it is possible to reduce coke consumption with efficient Pulverized Coal Injection system. We could see the importance of the conceptual / basic study and selection / definition of the scope for PCI upgrading service, because this step has a low cost but, if correctly executed, can have excellent technical, economic and environmental returns.

REFERENCES

- 1 R. Schott, F. Reufer - Efficiency Improvement of Reducing Agents in the Blast Furnace to Reduce CO₂ Emissions and Costs, Metec, Düsseldorf, Germany, 2015.
- 2 Reufer F. State of the art Drying and Grinding plants and Pulverized Coal Injection, Küttner Internal Event, Essen, Germany, 2016.
- 3 R. Schott, H.-K. Schott, C. Malek, Effizienzsteigerung des Hochofenbetriebs durch den Einsatz der Küttner Oxycoal-Technik, Vortrag bei der Jubiläumssitzung des VDI-GVC Fachausschusses „Hochtemperaturtechnik“, Düsseldorf, Februar 2008.
- 4 Barros J, Maier A, Costa F. Reduce CO₂ Emissions and Costs in Blast Furnace Operation with Pulverized Coal Injection. 48^o Seminário de Redução de Minérios e Matérias-primas. 2018; 48:134-144.
- 5 Barros J. A importância da Engenharia Básica para Correta Definição Técnica dos Sistemas e Equipamentos em Projetos de Investimento na Fundição. 19^o CONAF. 2022.
- 6 Barros J. Costa F. Sistemas de Captação, Exaustão, Limpeza de Gases e Recuperação Energética em Processos Siderúrgicos com Filtros de Mangas e Trocadores de Calor. 40^o Seminário de Balanços Energéticos Globais e Utilidades. 2019; 40:1-9.
- 7 Schott R. Reufer F. Küttner Reactive Pci® - Küttner Reactive Oxycoal® Patented Process to Increase Pci Rate into the Blast Furnace to Minimize Total Fuel Costs. 50^o Seminário de Redução de Minérios e Matérias-primas. 2022; 50:117-131.